

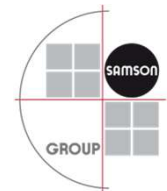

Series 280

Presented By: Christian Ritter





280 Series – Principle of Operation

- Steam flow reaches maximum velocity just after the throttling area
- Steam contacts the water at the inner edge of the flow divider
- The mesh structure of the flow divider III splits up the steam-water combination
- Steam velocity begins to decrease and heat is transferred to the water via the large surface area
- The steam-water mixture leaves the flow divider III as a thin fog with a high amount of steam
- Residual evaporation is completed downstream
- Since velocity at the vena contracta is independent of flow, atomization is ensured over the entire operating range

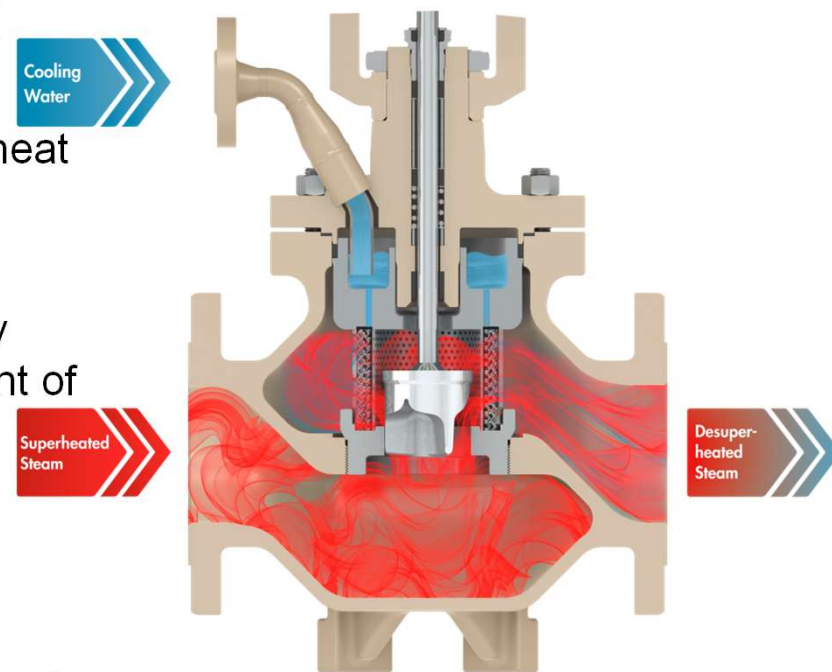



Steam Pressure and Temperature Control with Steam-Converting Valve

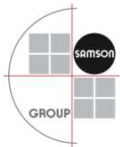
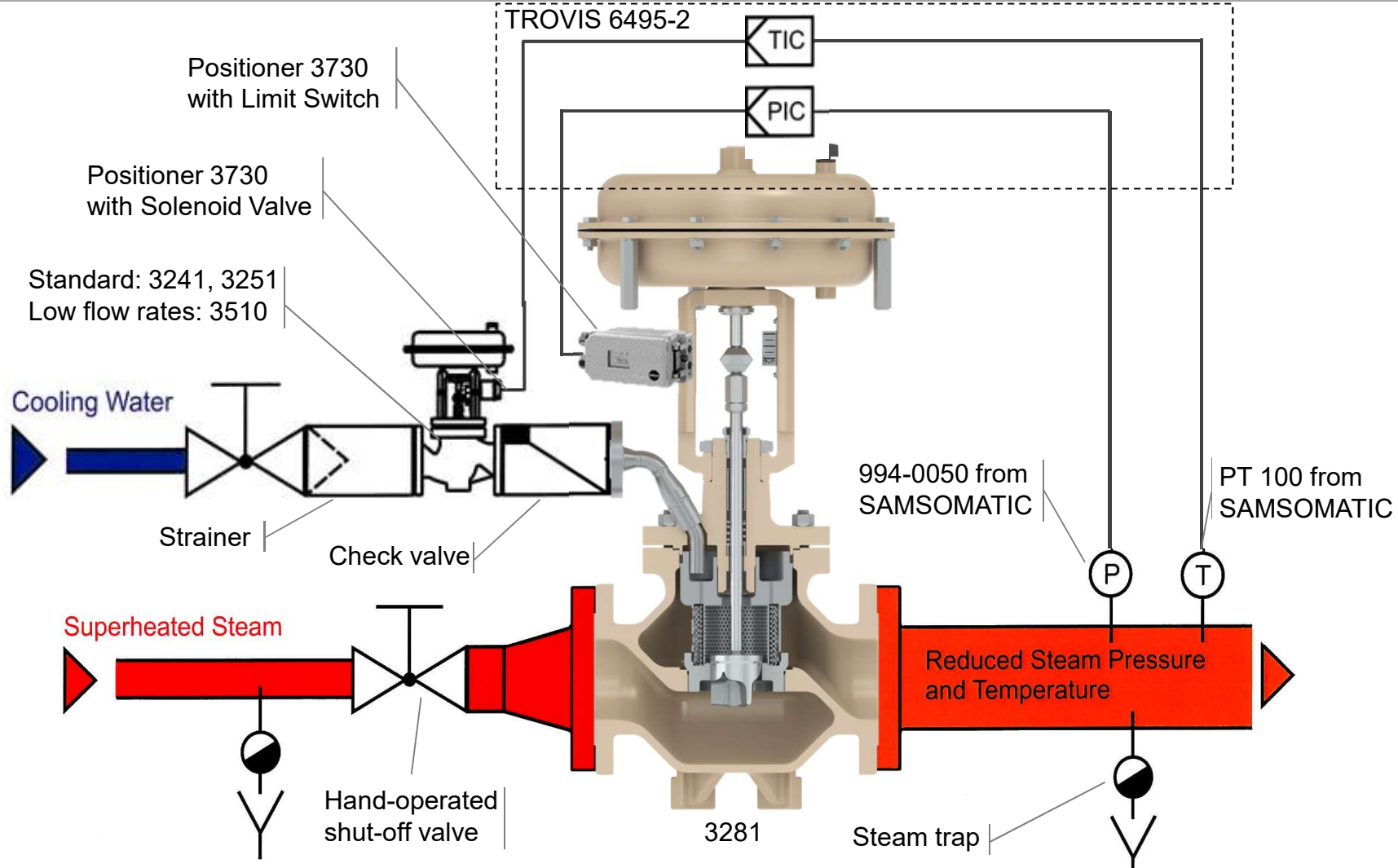



280 Series Steam Converting Valve

- Control valves to reduce steam pressure and temperature simultaneously
- Steam converters reduce the pressure and the temperature to the set point adjusted on the pressure and temperature controller

Nominal size	DN 50 – 500	NPS 2" – 20"
Nominal pressure	PN 16 – 160	Class 300 – 900
Temperature range	Up to 500°C	Up to 930°F
Material	WN 1.0619 WN 1.7357	A 216 WCC A 217 WC6

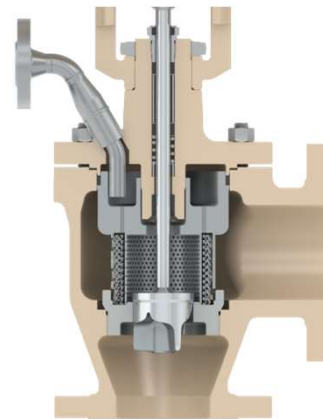
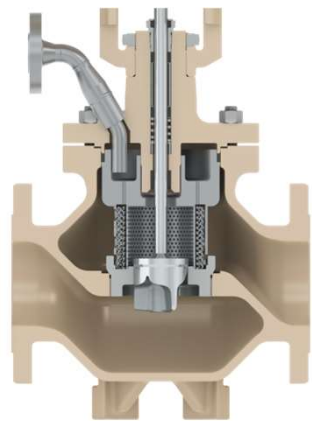



Comparison with Type 3251 Globe Valve

